

DRAWING MUST NOT BE SCALED  
REMOVE BURRS AND SHARP EDGES

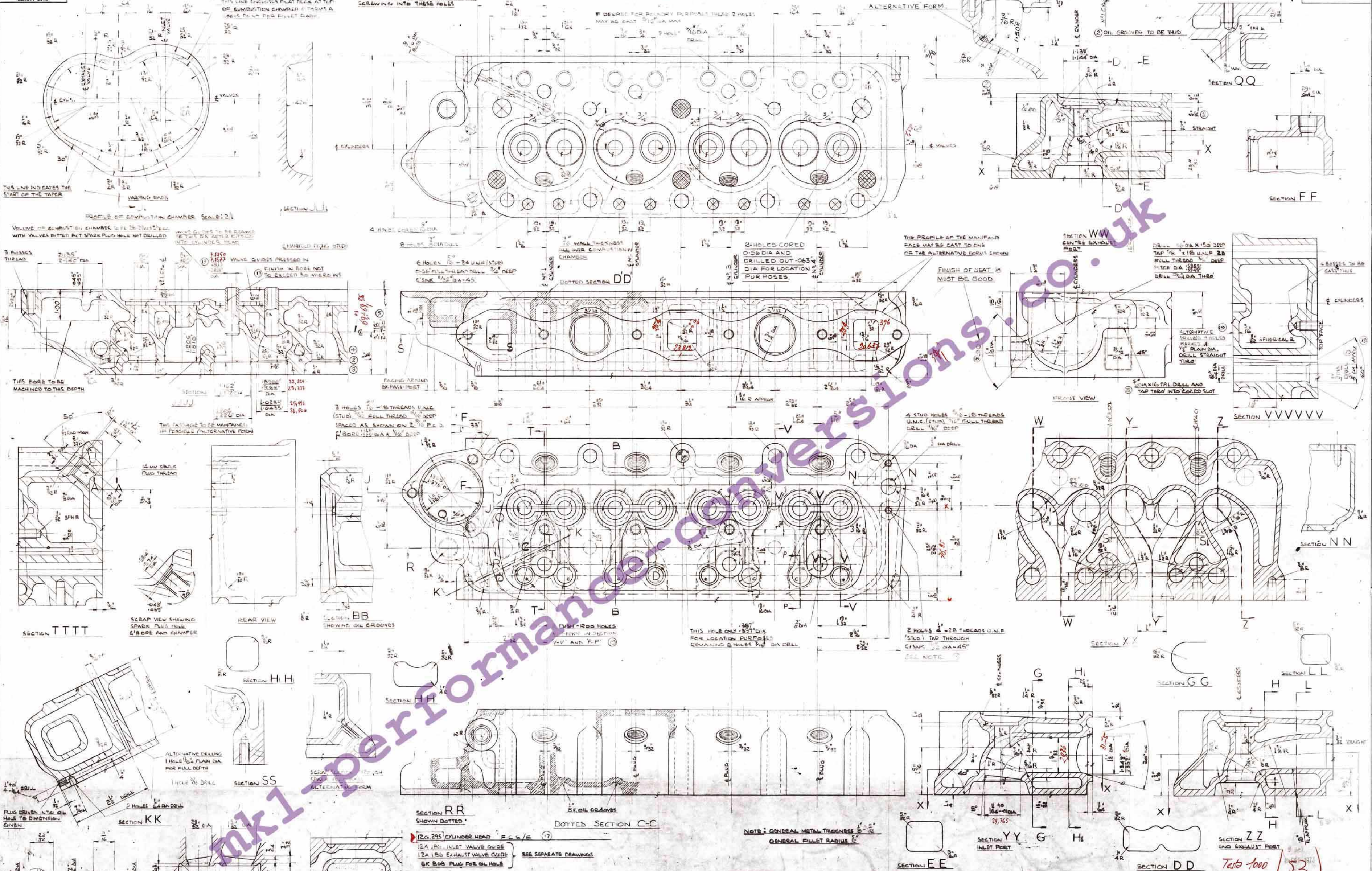

NO	REVISION	DATE	BY	CHKD	DESCRIPTION	REVISION	DATE	BY	CHKD	DESCRIPTION
22	1	11-7-73	AS	AS	SEE NOTE 60 DELETED	17	11-7-73	AS	AS	GENERAL MACHINING OF FLANGES & BUSHINGS TO BE WITHIN TOLERANCES OF 0.015 mm (0.0005 in) UNLESS OTHERWISE STATED
21	1	11-7-73	AS	AS	THERMOSTAT HOUSING MODIFIED	16	11-7-73	AS	AS	METAL PARTS SEMI OR FULLY FINISHED TO BE FREE FROM CORROSION CORROSION RESISTANT SURFACES TO BE TREATED WITH AN OILED PROTECTIVE
20	1	11-7-73	AS	AS	TRANSFER WITHOUT CHANGE	15	11-7-73	AS	AS	GENERAL SURFACE PROTECTION
19	1	11-7-73	AS	AS	22.422 22.422 22.422	14	11-7-73	AS	AS	GENERAL SURFACE PROTECTION

THIS LINE ENCLOSES FLAT DECK AT TOP OF COMBUSTION CHAMBER & FORMS A 90° POINT FOR BILLET FLASK.

NOTE: STUDS TO BE COATED WITH 'HYLOWAR' SOLE JOINTING COMPOUND BEFORE SCREWING INTO THESE HOLES.

IF DESIRED FOR PRIMARY PURPOSES THESE 2 HOLES MAY BE CAST 1/16 DIA.

ALTERNATIVE FORM

2 OIL GROOVES TO BE THIS

SECTION QQ

SECTION FF

SECTION WW

SECTION DD

SECTION VVVVVV

SECTION NN

SECTION XX

SECTION GG

SECTION LL

SECTION YY

SECTION ZZ

SECTION EE

SECTION DD

SECTION SS

SECTION RR

SECTION HH

SECTION TT

SECTION KK

SECTION JJ

SECTION II

SECTION III

SECTION IV

SECTION V

SECTION VI

SECTION VII

SECTION VIII

SECTION IX

SECTION X

SECTION XI

SECTION XII

SECTION XIII

SECTION XIV

SECTION XV

SECTION XVI

SECTION XVII

SECTION XVIII

SECTION XIX

SECTION XX

SECTION XXI

SECTION XXII

SECTION XXIII

SECTION XXIV

SECTION XXV

SECTION XXVI

SECTION XXVII

SECTION XXVIII

SECTION XXIX

SECTION XXX

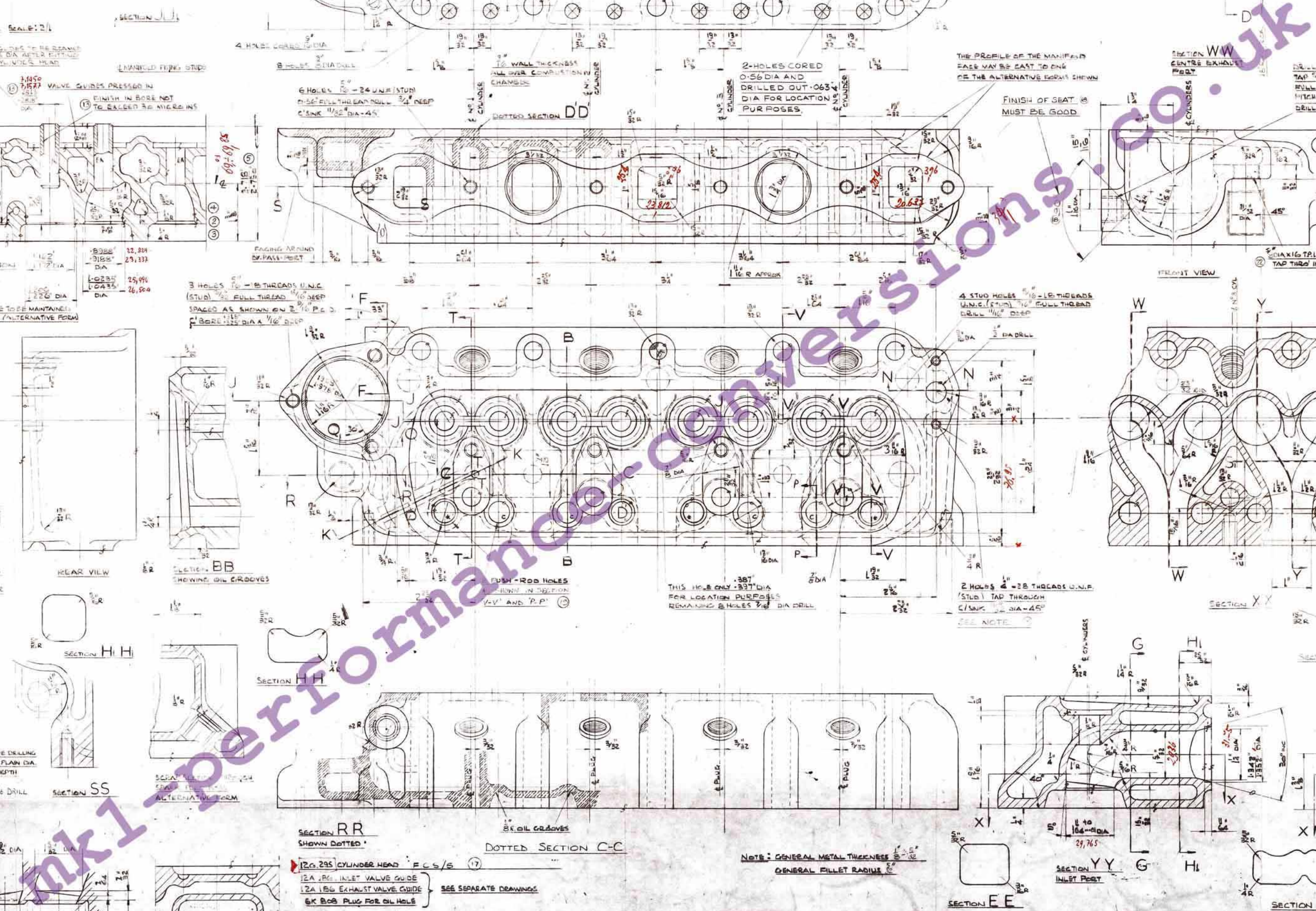

Tests 1000 / 53